



Technical comercial data

E-5.4-UN T.E-5.5

Serie ELEGANCE – Versión 07-02-2024

Approved UN 1H2/Y5.3/S Group II and III solids with inner bag,
marked with a danger triangle for blind people.

TECHNICAL DATA:

Material:	PP copolymer of first quality.
Colours:	White standard. Consult for other colours.
Useful Volume:	5.5 litres
Volume to the edge:	6.5 litres
Weight of the bucket:	178 g. approx.
Weight of the lid:	71 g. approx.
Weight of the handle (plastic):	8 g. approx.
Total Weight:	257 g. approx.
Decorative surface flat inks:	140 x 637 mm (height x perimeter)
Design surface photographic finish:	150 x 655 mm (height x perimeter)



MEASUREMENTS:

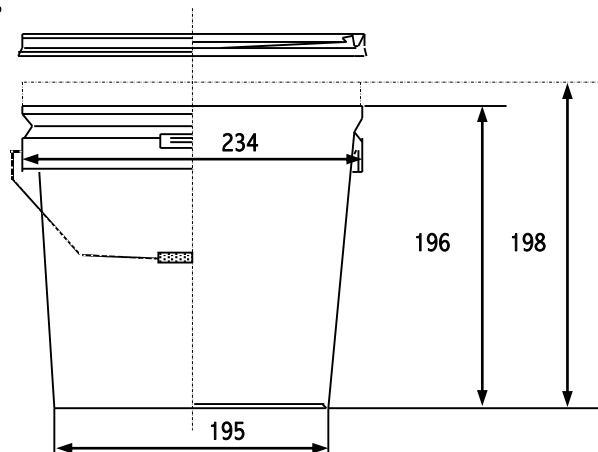

Measurements in millimetres

GROUPING OF TRANSPORT:

Buckets:	600 buckets per pallet
Pallet dimensions:	1180 x 960 x 1160 (see drawing)
Lids:	150 lids per box, this serves as a packaging of transportation
Box dimension:	480 x 240 x 960

